

INSTALLATION INSTRUCTIONS

Thank you for choosing Miracle Distribution Inc products.



This document contains Miracle Distribution Windows' recommended installation procedures for PVC and aluminum window systems featuring nailing fins or exterior trim applications. Not all window products are suitable for every wall assembly or construction condition. Always consult your local building authority to verify applicable codes, regulations, and installation requirements prior to installation.

Where local building codes differ from the recommendations contained in this guide, local code requirements shall take precedence.

Certain regions, including Florida and the Texas Department of Insurance (TDI) jurisdiction, may require specific anchoring methods based on product certifications and performance ratings. For project-specific requirements, refer to the applicable product approval documentation and follow the anchoring schedules indicated in the approved engineering drawings rather than the general fastening recommendations contained in this manual.

Modern construction techniques have significantly improved the air and water tightness of today's buildings. While these advancements enhance energy efficiency, they can also create negative air pressure conditions within the structure. This pressure differential may draw moisture through small openings in the building envelope. The Miracle Distribution Windows installation system is designed to integrate the window assembly with the building's weather-resistant barrier, typically the building wrap, to help manage moisture infiltration and support long-term building performance.

IMPORTANT INFORMATION & GLOSSARY

Please Note: These installation instructions are intended only for window systems featuring a horizontal flat sill and are not applicable to bow or bay window configurations. Any installation where the sill is located more than 35 feet above finished grade, or where the wall assembly or construction condition is not specifically addressed within this manual, must be reviewed and approved by a qualified architect or structural engineer.

Windows must be installed into openings that are square, level, and plumb. Failure to meet these requirements may adversely affect product operation, structural performance, weather resistance, and could result in the exclusion of warranty coverage for related issues.

Installer Notice: A copy of these installation instructions should be provided to the property owner upon completion of the installation. By installing this product, the installer acknowledges and accepts the terms, conditions, and limitations of the Miracle Distribution Windows Limited Product Warranty as part of the sale and installation of the product.

GLOSSARY

Applied Nailing Fin

A mechanically fastened vinyl attachment flange installed around the perimeter of a window frame and used to secure the window assembly to the rough opening. Products utilizing an applied nailing fin typically require additional fastening through the side jambs.

Buck

A wood-framed support structure installed within a masonry or concrete rough opening to provide a suitable mounting surface for windows or patio door systems.

Integral Nailing Fin

A fastening flange that forms part of the extruded frame or cladding system and is designed to secure the window directly to the rough opening.

Masonry Clip

A galvanized or corrosion-resistant metal fastening bracket used to anchor a window assembly to the surrounding structural framework or masonry opening.

Mulled Unit

An assembly consisting of two or more individual window units that have been structurally joined together to function as a single window system.

Precast Sill

A factory-manufactured concrete support component installed at the sill of a masonry or block wall opening to provide a stable bearing surface for the window.

Self-Adhered Flashing (SAF)

A waterproof membrane with an adhesive backing that is used to protect rough openings and create a weather-resistant seal between the window assembly and the building envelope. Self-adhered flashing should be

installed in a manner that promotes positive drainage and directs moisture from the wall cavity to the exterior of the structure.

Shiplap

A layered installation method in which each material overlaps the layer below it, allowing water to shed naturally toward the exterior and reducing the potential for moisture intrusion.

ROUGH OPENINGS

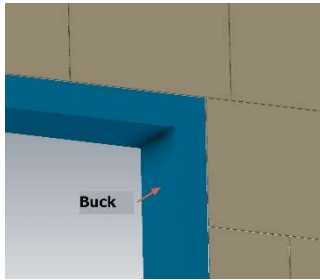

MASONRY / BLOCK WALL CONSTRUCTION

These installation procedures assume that a properly constructed wood-framed buck system has already been installed within the masonry or concrete wall opening. The buck must be securely anchored to the surrounding structure and fully sealed against moisture intrusion by a qualified building professional prior to window installation.

FULLY SHEATHED WALL CONSTRUCTION

In fully sheathed wall applications, the structural framing is enclosed with approved wall sheathing. The window assembly is installed with the nailing fin positioned directly against the face of the sheathing. These installation procedures assume that the building's weather-resistant barrier, including building wrap or equivalent materials, has been correctly installed prior to window installation.

OPEN-STUD CONSTRUCTION

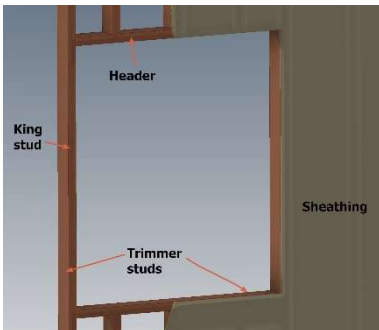

Sheathed Wall

For open-stud wall applications, a suitable backing support system must be installed around the entire perimeter of the rough opening before the weather-resistant barrier is applied. The window assembly will be installed with the nailing fin positioned flush against the backing support.

Where self-adhered flashing extends beyond the width of the wall framing, additional backing support may be required to fully support the flashing material across its entire width.

Backing support materials shall be non-water-degradable and should not exceed 1/8 inch (3 mm) in thickness. Suitable materials include fiber-reinforced plastic (FRP), lauan plywood, exterior-grade plywood, or other approved substrate materials. The backing support must completely surround the rough opening to provide a continuous mounting and flashing surface.

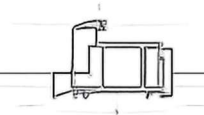

SAFETY AND HANDLING

SAFETY

- Carefully read and understand all installation instructions, product documentation, and manufacturer recommendations before beginning work. Failure to follow approved installation procedures may affect product performance and could result in the limitation or denial of warranty coverage.

- Window installation should not be performed by a single individual. A minimum of two qualified installers is recommended. Always use proper lifting techniques and handling procedures.

- Exercise caution when handling glass products. Damaged, cracked, or broken glass can cause serious personal injury.

- Wear appropriate personal protective equipment (PPE) at all times, including safety glasses, gloves, hearing protection, and other site-specific safety equipment.
- Operate all hand tools and power tools in accordance with the manufacturer's safety instructions and operating guidelines.
- Use additional caution when working on elevated surfaces, scaffolding, ladders, or multi-story installations.
- When working in renovation environments where existing painted surfaces may be disturbed, follow all applicable regulations regarding lead-based paint. Buildings constructed before 1979 may contain lead-based coatings. Consult local regulatory authorities for guidance regarding safe handling and disposal procedures.
- **WARNING:** Cutting, drilling, sanding, machining, or modifying wood-based products may generate airborne wood dust. Use approved respiratory protection and appropriate dust-control measures to minimize exposure.

MATERIALS AND WINDOW HANDLING

- Ensure all operable window panels, sashes, and locking mechanisms are secured prior to installation.

IMPORTANT

IF AN INJURY OCCURS DURING INSTALLATION OR HANDLING, SEEK IMMEDIATE MEDICAL ATTENTION.

MATERIALS AND TOOLS

NEEDED MATERIALS

For Muller Units or Window Systems Without Exterior Trim or a Sill Nailing Fin

- Masonry clips
- #8 x 3/4" screws for securing masonry clips to the window frame
- #8 corrosion-resistant screws for fastening masonry clips to the structure. Fasteners must penetrate a minimum of 1" into the framing or supporting substrate.

For Installations into Stud-Framed Wall Construction

- 4", 6", or 9" wide self-adhered flashing membrane, as required by local building codes, project specifications, and window configuration. A high-performance butyl flashing tape or approved equivalent is recommended.
- Spray adhesive or primer compatible with the selected self-adhered flashing system and approved by the flashing manufacturer.

For Installations into a Wood Buck System

- Liquid-applied flashing membrane or equivalent waterproofing system approved for rough opening preparation.

Installation Materials

Miracle Distribution Windows products should be installed in accordance with the installation procedures and flashing details supplied with the product. Alternative flashing systems and installation methods may be used where permitted by project specifications, local building regulations, and manufacturer recommendations. In such cases, installation shall be completed in accordance with the flashing manufacturer's published instructions.

Always follow the material manufacturer's recommendations regarding proper application, handling, storage, and compatibility. Where flashing membranes, primers, sealants, and foam products are used together, utilizing products from the same manufacturer is recommended to help ensure system compatibility.

- Follow the handling, storage, application, and installation instructions provided by all material manufacturers.
- Protect flashing, sealants, tapes, and adhesive-backed materials from contamination by dirt, moisture, excessive heat, direct sunlight, and accidental folding or creasing.
- Always transport and handle windows in an upright, vertical position. Do not carry windows flat or drag them across floors or other surfaces.
- Avoid placing excessive stress on frame corners, joints, mullions, or sash components during handling and installation.
- Store window units in a dry, well-ventilated location in a vertical, slightly inclined position to allow adequate airflow. Do not stack windows horizontally.
- Protect stored products from prolonged exposure to direct sunlight and adverse weather conditions.
- Install window systems only into vertical wall assemblies and only when wall substrates, framing members, sheathing, and weather-resistant barriers are dry and suitable for installation.

It is the responsibility of the installer, contractor, architect, or building owner to verify compatibility between all materials and the substrates to which they are applied.

- 3" galvanized casing nails for windows with exterior trim, or 1-3/4" galvanized roofing nails for nailing fin applications. Fasteners must penetrate a minimum of 1-1/4" into structural framing, or as required by local code.
- #8 x 3" corrosion-resistant screws for window systems rated DP50 and above, including impact-rated products.
- Galvanized drip cap flashing or factory-supplied drip cap.
- High-performance exterior sealant suitable for window installation applications. Sealant should be paintable and available in color-matched options where required.
- Backer rod sized approximately 1/8" larger than the widest portion of the joint being sealed.
- Low-expansion polyurethane window and door foam approved for fenestration installations.
- Non-compressible, moisture-resistant shims.

NEEDED TOOLS

- Utility knife
- J-roller
- Hammer
- Tape measure
- Caulking gun
- Level (minimum 4' recommended)
- Drill with 1/8" tapered drill bit and 3/8" countersink bit
- Screwdrivers
- Additional tools and equipment as required by project conditions and local installation requirements.

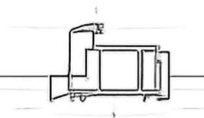

REMOVE PACKAGING AND INSPECT WINDOW

REMOVE PACKAGING

Carefully remove all shipping materials, including corner protectors, transport blocks, protective pads, packaging straps, and other temporary shipping components.

If protective film has been applied to the glass or frame surfaces, leave the film in place until installation is complete and all construction activities that may damage the window have been finalized.

Remove or trim any exposed staples, fasteners, or packaging remnants that may interfere with handling or installation.

Note: Double-hung window systems may be supplied with interior shipping bands or sash-retention straps. These components should remain in place until the window has been properly installed and secured within the rough opening. Retaining these bands during installation helps maintain sash alignment and frame squareness.

INSPECT WINDOW

Before installation, carefully inspect the window assembly for the following:

- Cosmetic defects, including scratches, dents, finish damage, discoloration, or glazing imperfections.
- Frame squareness. The difference between diagonal measurements should not exceed 1/4" (6 mm).
- Damage resulting from shipping, handling, or storage.
- Cracks, chips, or other visible defects in glass components.
- Proper operation of moving parts, locks, hardware, and sash components.

Do not install any product that exhibits visible damage, structural defects, or conditions that may affect performance. Report any concerns to the supplier or authorized distributor before proceeding with installation.

INSPECT ROUGH OPENING

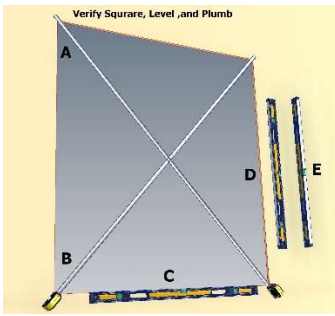

Verify Square, Level, and Plumb

Prior to installation, verify that the rough opening dimensions, alignment, and structural conditions comply with the requirements outlined below.

- Confirm that both the width and height of the window unit are between 1/2" and 5/8" smaller than the corresponding rough opening dimensions. For muller window assemblies, the overall unit width should be approximately 3/4" less than the rough opening width.
- Verify that the rough opening is square by comparing diagonal measurements (A) and (B). Both measurements should be equal. Maximum allowable deviation from square is 1/8" for window units measuring 20 sq. ft. or less, and 1/4" for window units exceeding 20 sq. ft.
- Confirm that the rough opening is plumb, level, and properly aligned at all reference points (C, D, and E). Maximum allowable deviation is 1/16" for every 2 feet of opening dimension and shall not exceed 1/8" overall.
- Inspect the rough opening sill to ensure it is level or positively sloped toward the exterior. The sill must not be crowned, bowed, or sagged.
- Verify that the exterior face of the rough opening is positioned within a single plane and does not exceed 1/8" of twist from corner to corner.
- Confirm that structural framing requirements have been met. A minimum double-stud configuration, including king studs and jack (trimmer) studs, should be used to adequately support the header above all rough openings.

FOR RETROFIT INSTALLATIONS

After removal of the existing window system, carefully remove sufficient exterior cladding materials, including siding, stucco, trim, or other finishes, to expose an adequate area of intact weather-resistant barrier for proper integration with the new window flashing system.

Inspect the existing building wrap and surrounding substrates for damage. Where damage is present, repair or replace the affected weather-resistant barrier using a shiplap installation method to maintain proper water management and drainage.

Verify that the rough opening framing, supporting structure, and surrounding wall assembly are structurally sound and suitable for installation of the new window system.

Dispose of or recycle removed windows, glazing, and construction materials in accordance with applicable local regulations and waste management requirements.

PREPARE BUCK

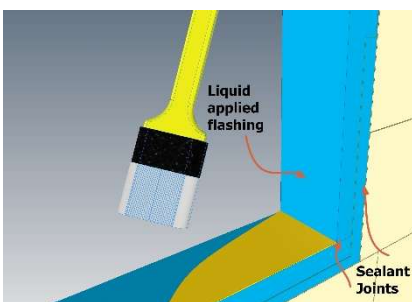

Note: This section applies only to installations into masonry or concrete wall construction utilizing a wood buck system. For installations into stud-framed wall construction, proceed directly to **Section 4: Prepare Stud-Framed Wall**.

1. Inspect the buck assembly and seal all joints, gaps, or openings greater than 1/16" between the buck components and between the buck and the surrounding concrete or masonry structure using an approved sealant.
2. Apply a liquid-applied flashing membrane to the head and jamb areas of the buck and extend the flashing onto the adjacent masonry or concrete surfaces as

illustrated.

3. Where a four-sided buck system is present, apply the same flashing and sealing procedures to the sill area to provide continuous moisture protection.

Note: Where the window assembly will bear directly on the sill, install shims to provide continuous support beneath the window frame. The shimming material shall be at least the full width of the window frame and a minimum of 1/4" narrower than the depth of the window sill frame member. Shims should be used to level the rough opening sill and shall not exceed 1/4" in thickness.

4. Position the sill shims flush with the exterior edge of the opening and center them between the side jambs. For mullered window assemblies, install additional support shims directly beneath each mull joint. Secure shims in place using sealant or another approved fastening method to prevent movement during installation.

After completing these steps, proceed to **Section 5: Prepare Window.**

PREPARE STUD-FRAMED WALL

PREPARE BUILDING WRAP

Note: Consult the manufacturer of the weather-resistant barrier (building wrap) prior to installation to confirm that the following procedures comply with their installation requirements and do not affect product warranty coverage.

1. Trim the building wrap neatly along the perimeter of the rough opening so that it is flush with the framing.
2. At the head of the opening, make a 45° diagonal cut in the building wrap and temporarily secure the upper flap out of the way using compatible tape, as illustrated.
3. Trim the building wrap along both side jambs as required to allow the window nailing fin to be installed directly against the wall sheathing without obstruction.

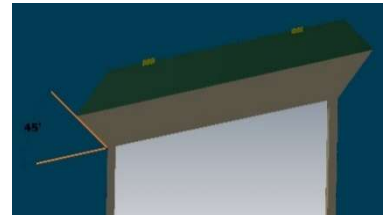

Proper preparation of the building wrap is essential to ensure correct integration of the window flashing system with the weather-resistant barrier and to promote effective water management within the wall assembly.

PREPARE / SHIM THE SILL

1. Install a self-adhered flashing membrane across the sill area to provide a continuous waterproof barrier.
2. The flashing shall extend to provide a minimum of 2" of exposed material below the window nailing fin. The flashing width must be no less than the combined dimension of $A + B + 1-3/4"$.
3. Measure the frame dimension from the interior face of the window to the nailing fin or exterior trim (**Dimension A**) and subtract 1/4". Transfer this measurement from the exterior edge of the rough opening sill and mark a continuous reference line across the entire sill. This line indicates the location of the rear edge of the flashing membrane.
4. Cut a section of flashing equal to the length of the sill plus an additional 12".

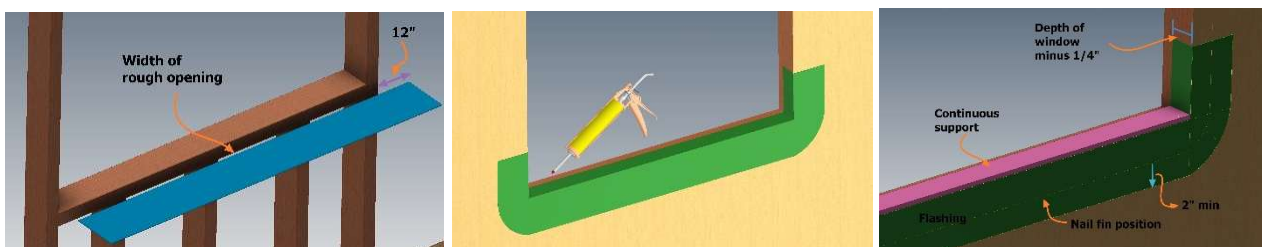
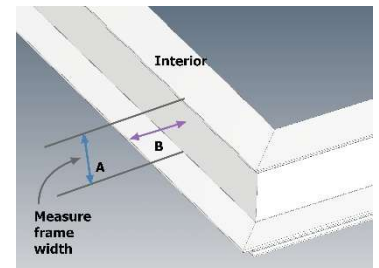

5. Position the flashing on the rough opening sill, extending the flashing a minimum of 6" up each side jamb as illustrated.
6. Remove the release liner and firmly place the flashing into position.
7. Fold the flashing down over the exterior wall surface. Secure mechanically where required by the flashing manufacturer or project conditions.
8. Using a J-roller, firmly press the flashing to the substrate to eliminate wrinkles, bubbles, and voids. Remove and replace the flashing if proper adhesion cannot be achieved.
9. Install continuous sill support as follows:

Note: Where the window frame will bear directly on the sill, install shims to provide continuous structural support beneath the window. The shim material shall be at least the width of the window frame and a minimum of 1/4" narrower than the depth of the window sill frame member. Shims should level the rough opening sill and shall not exceed 1/4" in thickness.

10. Position the sill shimming flush with the exterior edge of the opening and center it between the side jambs. For mullered window assemblies, install additional shims beneath each mull joint. Secure shims in place using sealant or another approved method to prevent movement during installation.

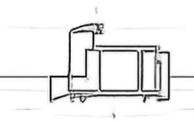

PREPARE WINDOW

SEPARATELY SUPPLIED DRIP CAP

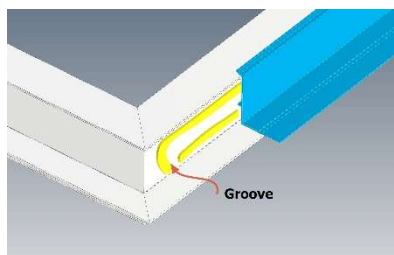

Note: This procedure applies only to window systems equipped with a nailing fin. Window units supplied with exterior trim will have the drip cap installed during **Section 6: Install Window**.

Apply a continuous 1/4" bead of approved sealant across the header as illustrated. Position the drip cap into the designated groove and carefully tap it into place using a wood block or other non-marring installation tool to prevent damage to the finish.

INSTALL MASONRY CLIPS ON THE SILL

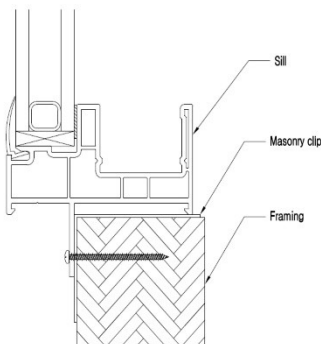

Note: Masonry clips are required for window units that do not incorporate exterior trim or a nailing fin along the sill.

1. Install masonry clips beginning 4" from each corner of the window frame and continue at 16" on-center spacing across the sill. Secure each clip using two #8 x 3/4" screws.

Ensure all clips are properly aligned and securely fastened before proceeding with installation.

SEAL WINDOW

- For window units supplied with exterior trim, inspect the sealant joint located on the interior side of the frame where the trim interfaces with the window assembly.
- Apply additional sealant where necessary to ensure a continuous, watertight seal around the perimeter of the trim and frame connection.
- Verify that all joints are fully sealed prior to installation to help prevent water infiltration and maintain long-term weather resistance.

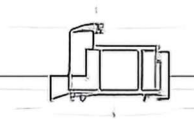

INSTALL WINDOW

WARNING: To reduce the risk of personal injury, window installation should be performed by a minimum of two qualified installers. The window unit must be adequately supported and stabilized until all required fasteners have been installed and secured.

Certain jurisdictions, including Florida and the Texas Department of Insurance (TDI) region, may require project-specific anchoring methods based on product approvals, engineering certifications, and performance ratings. For product-specific anchoring requirements, visit [www.Miracle Distributionwindow.com](http://www.MiracleDistributionwindow.com) and follow the fastening schedules and engineering details provided for the applicable product rather than the general fastening recommendations contained in this manual.

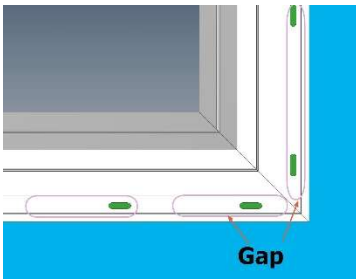

Note: All fastener or anchor heads must sit flush with the surface. Do not overdrive fasteners or deform the nailing fin during installation.

1. Apply a continuous 3/8" bead of approved sealant along the interior side of the nailing fin or exterior trim at both side jambs and across the head of the window. At the sill, leave a minimum 2" gap in the sealant bead every 8" to allow for drainage.

2. Carefully position the window onto the prepared sill support and tilt the unit into the rough opening. Ensure that the sill is fully supported by the continuous shimming system and that the window is properly seated.

3. Install the first fastener through the nailing fin or exterior trim between 3" and 7" from one upper corner to temporarily secure the unit in position.

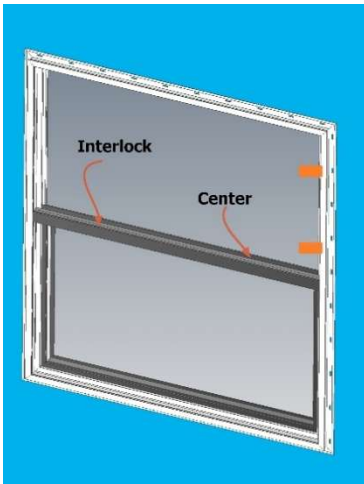
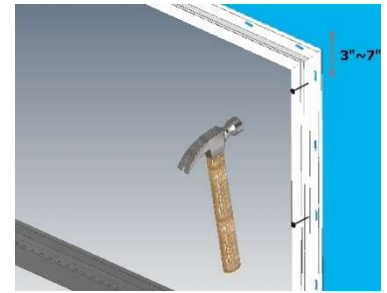

4. Install shims at each interlock location, or at the center of the unit where applicable, and within 4" to 6" of each corner along the side jambs and head jamb. Add additional shims as required to maintain proper alignment and to ensure the window remains square, level, and plumb within the opening. Larger window units may require additional shimming points. Shims may be secured using sealant or a compatible adhesive.

5. Verify that the window is square, level, and plumb. Operate all moving components to confirm smooth and proper operation. If the unit does not operate correctly, remove and reinstall the window as necessary before proceeding.

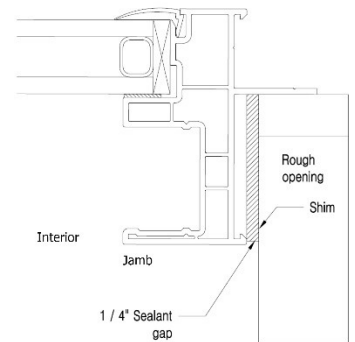

SECURE WINDOW

1. Secure the window assembly through the exterior trim or nailing fin, beginning 4" from each corner and continuing at 8" on-center intervals around the entire perimeter of the window.

For Window Units with Applied Clad Trim Covering the Nailing Fin

2. From the interior side of the window, secure the unit through the jambs using the following procedure:

- Mark fastener locations 4" from each corner and at 8" intervals around the perimeter of the frame.

- At each marked location, drill a pilot hole through the side jamb and into the structural framing. Countersink each hole as required for wood filler or decorative plug covers.

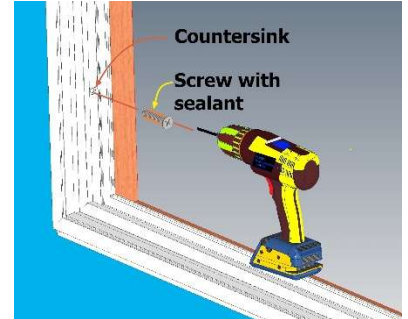

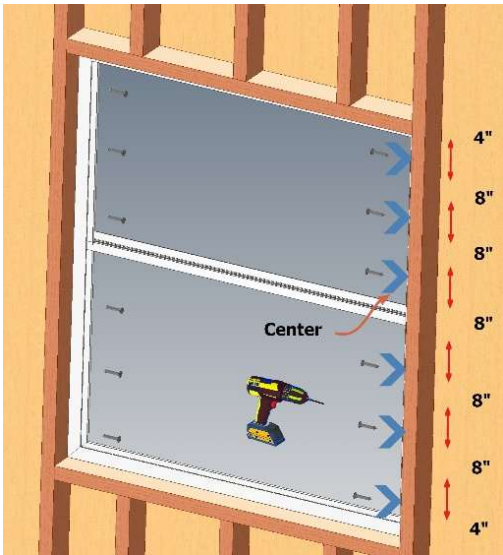

- Apply an approved sealant to the threads of each #8 x 3" screw before installation, then drive the screw through the jamb and securely into the framing.
3. Where masonry clips are utilized, install two #8 screws through each clip and into the supporting framing. Fasteners must penetrate the structural framing by a minimum of 1".
 4. Hung window systems must be secured through the jamb adjusters using the supplied #8 x 2" screws. Adjust and straighten the jambs in accordance with the instructions provided with the hardware.
 5. Window units equipped with an applied nailing fin and/or carrying a DP50 performance rating or higher, including impact-rated products, must be mechanically fastened through the side jambs and head. Install #8 x 3" screws 4" from each corner and at 8" intervals as illustrated. All screws must fully penetrate any installed shims and extend into the structural framing to provide proper anchorage.

APPLY DRIP CAP TO WINDOWS WITH EXTERIOR TRIM

1. Cut the drip cap to a length equal to the width of the header trim plus an additional 1/4", providing approximately 1/8" of overhang beyond each end of the trim.
2. Apply a continuous 1/4" bead of approved sealant along the top surface of the header trim as illustrated.
3. Position the drip cap centrally over the header trim and secure it in place using the appropriate fasteners.
4. Apply sealant beneath the drip cap at both ends where it interfaces with the exterior trim to ensure a continuous weather-resistant seal.
5. Secure the drip cap through the upturned fastening leg as illustrated, ensuring it is firmly anchored and properly aligned.

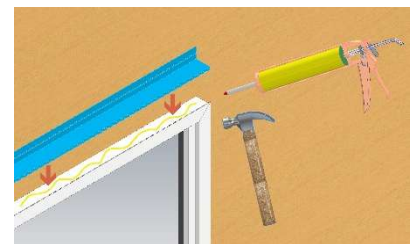

Note: Verify that the drip cap is installed level and that all sealant joints are continuous to promote proper water drainage and long-term weather protection.

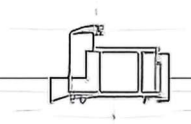

FLASH WINDOW

WINDOWS WITH A NAIL FIN INSTALLED INTO STUD-FRAMED WALL CONSTRUCTION ONLY

Note: This flashing procedure applies exclusively to window systems equipped with a nailing fin and installed into stud-framed wall assemblies. Flashing materials shall be installed in a shiplap configuration to promote positive drainage and direct moisture to the exterior of the wall system.

Minimum Flashing Length Requirements

Flashing Component	PG50 or Below (4" Flashing)	Above PG50 (6" Flashing)
Header Flashing	10" longer than the header	14" longer than the header
Side Flashing (Each Side)	8" longer than the jamb	12" longer than the jamb

Flashing Installation Requirements

- Ensure all nailing fins are securely fastened and that the window has been verified as square, level, plumb, and fully operational before beginning the flashing process.
- Install flashing materials in the proper sequence, beginning at the sill, followed by the jambs, and finally the head flashing.

- Flashing materials shall extend beyond the window frame dimensions as indicated in the table above.
- Side flashing pieces must overlap the sill flashing, and head flashing must overlap the side flashing to maintain proper shiplap water-shedding principles.
- Firmly roll all flashing materials using a J-roller to eliminate wrinkles, voids, fishmouths, and trapped air pockets.
- Replace any damaged, contaminated, or improperly adhered flashing materials before proceeding with the installation.
- Ensure all flashing components are fully integrated with the weather-resistant barrier to create a continuous moisture-management system around the window opening.

SPRAY ADHESIVE / PRIMER

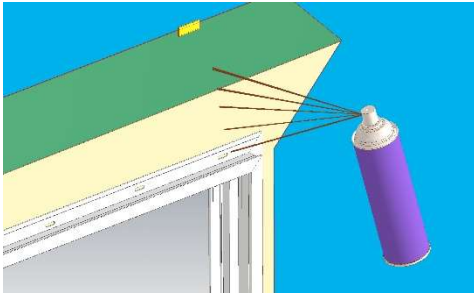

Note: A spray adhesive or primer may be required depending on the selected flashing system, substrate conditions, and manufacturer's recommendations. Always refer to the flashing manufacturer's installation instructions to determine whether a primer is necessary and to identify approved applications.

Protect the window frame, glass, and surrounding finished surfaces from overspray before application.

Apply the spray adhesive or primer in accordance with the manufacturer's instructions to the nailing fin and the surrounding weather-resistant barrier (building wrap) as illustrated. Allow the primer to cure or flash off as specified before installing the self-adhered flashing membrane.

APPLY SELF-ADHERED FLASHING

Note: Position the edge of the self-adhered flashing as close to the window frame as practical while ensuring complete coverage of the nailing fin.

Note: The dimensions listed below are based on the use of 4" wide flashing tape. When wider flashing materials are used, adjust dimensions accordingly while maintaining proper overlap requirements.

1. Install the side flashing pieces first. Begin each piece approximately 3" above the window header and extend the flashing downward so that it overlaps the sill flashing as illustrated.
2. Install the drip cap where required. Pre-drill through the nailing fin if necessary to facilitate proper fastening and alignment.
3. Center the header flashing above the window and apply it so that it fully overlaps the side flashing pieces, maintaining proper shiplap water-shedding principles.
4. Firmly roll all flashing materials using a J-roller to ensure complete adhesion. Remove any wrinkles, air pockets, gaps, fishmouths, or trapped bubbles. If proper adhesion cannot be achieved, remove the flashing and install a new section.
5. Verify that all flashing components are securely bonded to the substrate and integrated with the weather-resistant barrier to create a continuous moisture-management system around the window opening.

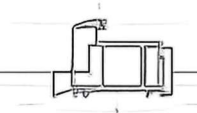
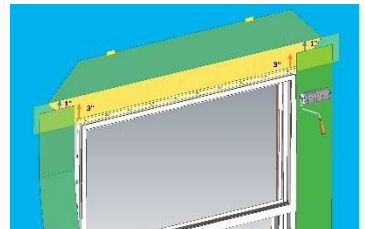
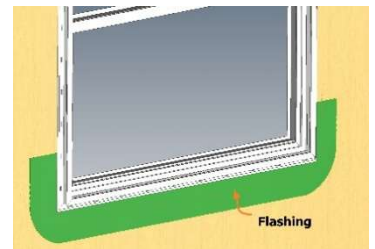

COMPLETE INSTALLATION

1. Release the weather-resistant barrier (building wrap) previously secured above the window header and fold it down so that it overlaps the installed header flashing. Seal all exposed cuts and termination points using compatible self-adhered flashing or approved building wrap tape.
2. Apply a continuous 3/8" bead of sealant at all four corners of the window assembly. Tool the sealant into a smooth fillet profile to ensure a continuous weather-resistant seal.
3. Seal all gaps, voids, and exposed openings located at the ends of horizontal mullion joints using an approved exterior-grade sealant.

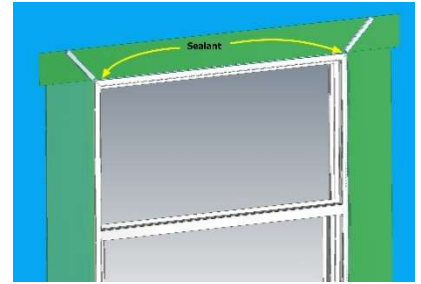

CONTINUOUS AIR SEAL

Create a continuous interior air barrier by sealing the space between the window frame and rough opening.

This may be accomplished using low-expansion polyurethane window and door foam, or by installing backer rod and sealant where appropriate. Ensure the air seal is continuous around the entire perimeter of the window assembly to minimize air infiltration and improve energy performance.

AFTER INSTALLATION

- Install the exterior wall finish system in accordance with the cladding manufacturer's installation requirements and applicable building codes.
- Maintain an expansion and contraction gap of approximately 3/8" between the window frame and the finished exterior wall surface, including siding, stucco, masonry veneer, or other cladding systems. For improved appearance and weather protection, seal side gaps using backer rod and sealant. Where sealant is applied above the drip cap, the sealant bead should remain discontinuous to allow for proper drainage.
- Remove any protective film applied to frame cladding immediately following installation. Protective film applied to glass surfaces should be removed within one year of installation.
- Protect newly installed window units from construction-related damage caused by plaster, stucco, paint, masonry work, or other finishing operations. Where necessary, cover the window assembly with protective plastic sheeting during construction activities.
- Finish, seal, stain, or paint all exposed wood components promptly following installation in accordance with the finish manufacturer's recommendations.
- Upon completion of installation, verify proper window operation, confirm that all fasteners and sealant joints are secure, and ensure that all drainage paths remain unobstructed.

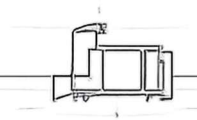

For warranty coverage, product care, maintenance guidelines, and additional technical resources, please visit the Miracle Distribution Windows website at www.miraclewindow.com or contact your authorized Miracle Distribution Inc representative.

Proper installation, routine maintenance, and adherence to the recommendations contained in this manual will help ensure long-term product performance, durability, and customer satisfaction.

Thank you for choosing Miracle Distribution Inc.

Engineered for Performance. Designed for Texas. Built to Last.